

ASSEMBLY INSTRUCTIONS

**MODEL : KATE
KING BED (4 + 8)**

(Box 1)
BOX OF HEADBOARD & FOOTBOARD

| No | ITEM | Qty |
|----|---------------------|-------|
| A | Headboard | 1 pc |
| B | Footboard | 1 pc |
| C | Headboard Leg (L/R) | 2 pcs |
| D | Bed Slat | 4 pcs |
| E | Bed Slat Support | 8 pcs |

(Box 2)
BOX OF SIDE RAIL

| No | ITEM | Qty |
|----|-----------|-------|
| F | Side Rail | 2 pcs |

(Box 1)
HARDWARE LIST

| No | ITEM | Qty |
|----|--------------------------------------|-------|
| 1 | Csk M4 x 32mm | 8 pcs |
| 2 | JCBC M6 x 30mm | 6 pcs |
| 3 | SPRING WASHER 1/4" Rbw | 6 pcs |
| 4 | Flat Washer 1/4" ID x 13mm OD Blk | 6 pcs |
| 5 | ALLEN KEY m4x65mm Blk | 1 pc |

STEP 1 : Attach Head Board Leg (C) to Head Board (A) as shown using JCBC BOLT (2) with Spring Washer (3), Flat washer (4) and securing with ALLEN KEY (5).

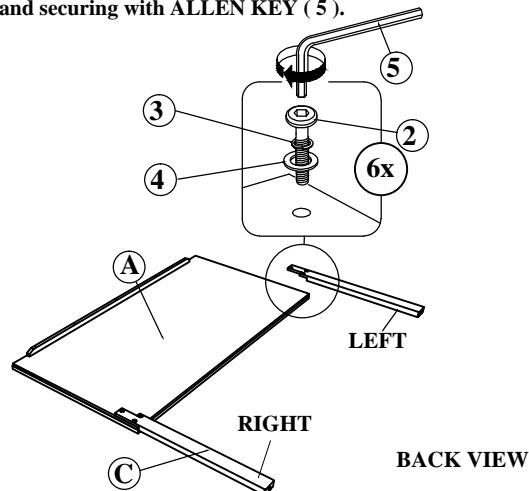

STEP 2 : Hook SIDE RAIL (F) TO HEAD BOARD (A) closely and push down to fit. repeat step 2 with other end of rail to hook onto FOOTBOARD (B).

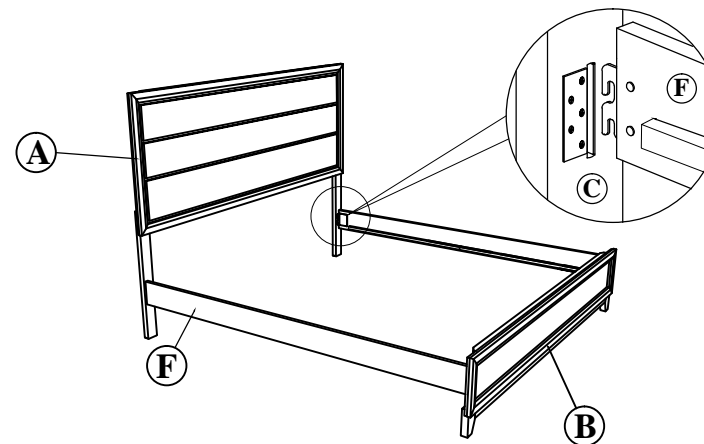

STEP 3 : Fix the Bed Slats Support (E) to Bed Slats (D) as Shown and fix the Bed Slats to Side Rail (F) by using CSK Screw (1). Loosen or Tighten the Adjuster as necessary to level the bed. Bed assembly should be done in final location to ensure stability.

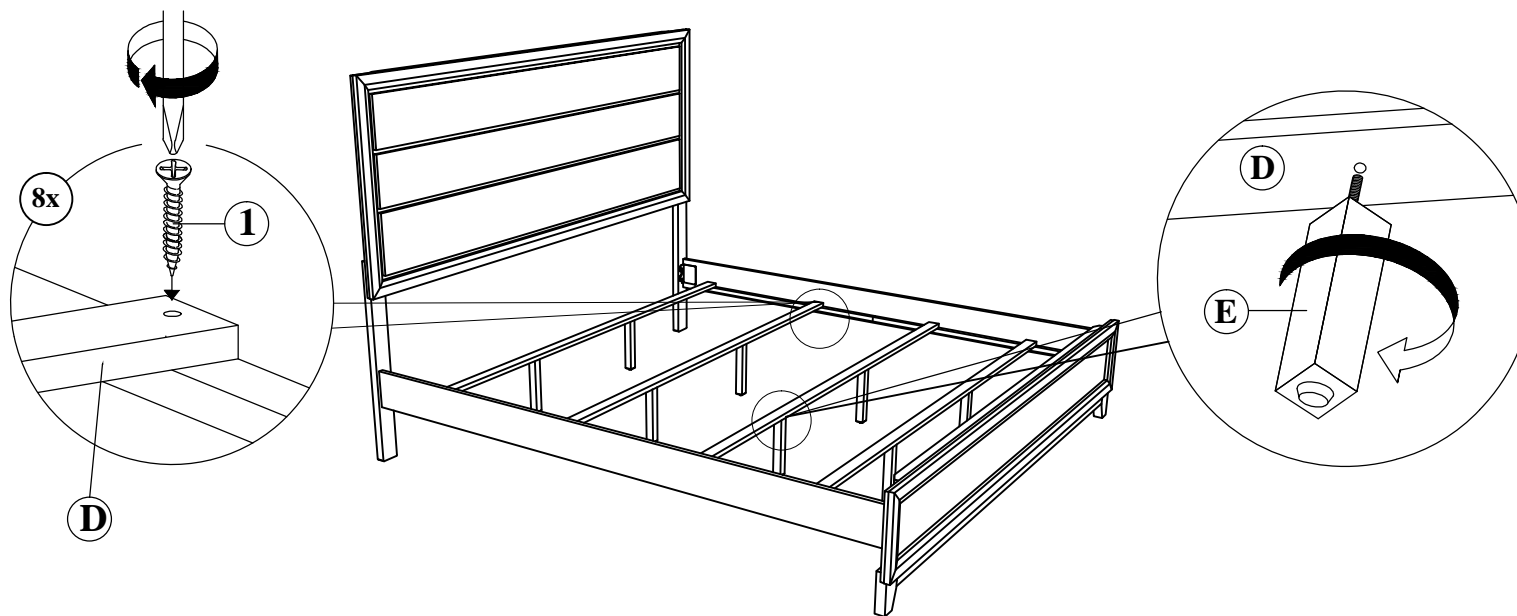

NOTE : MUST TIGHTEN SCREWS PERIODCALLY WITH USE SCREW WILL BECOME LOOSE CHECK TIGHTNESS OF ALL SCREW EVERY 6-8 WEEKS.

ASSEMBLY INSTRUCTIONS

MODEL : KATE
QUEEN & FULL BED (4 + 4)

(Box 1)
BOX OF HEADBOARD & FOOTBOARD

| No | ITEM | Qty |
|----|---------------------|-------|
| A | Headboard | 1 pc |
| B | Footboard | 1 pc |
| C | Headboard Leg (L/R) | 2 pcs |
| D | Bed Slat | 4 pcs |
| E | Bed Slat Support | 4 pcs |

(Box 2)
BOX OF SIDE RAIL

| No | ITEM | Qty |
|----|-----------|-------|
| F | Side Rail | 2 pcs |

(Box 1)
HARDWARE LIST

| No | ITEM | Qty |
|----|--------------------------------------|-------|
| 1 | Csk M4 x 32mm | 8 pcs |
| 2 | JCBC M6 x 30mm | 6 pcs |
| 3 | SPRING WASHER 1/4" Rbw | 6 pcs |
| 4 | Flat Washer 1/4" ID x 13mm OD Blk | 6 pcs |
| 5 | ALLEN KEY m4x65mm Blk | 1 pc |

STEP 1 : Attach Head Board Leg (C) to Head Board (A) as shown using JCBC BOLT (2) with Spring Washer (3), Flat washer (4) and securing with ALLEN KEY (5).

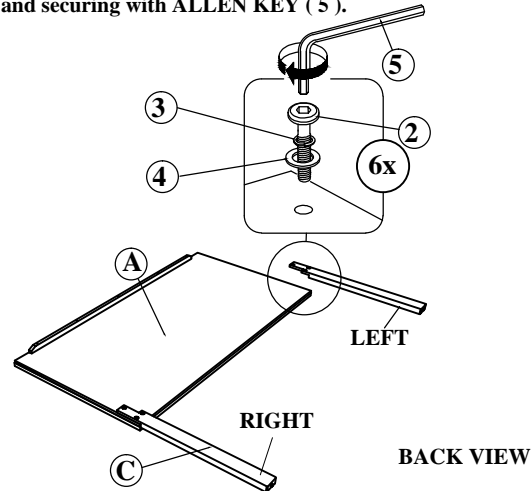

STEP 2 : Hook SIDE RAIL (F) TO HEAD BOARD (A) closely and push down to fit. repeat step 2 with other end of rail to hook onto FOOTBOARD (B).

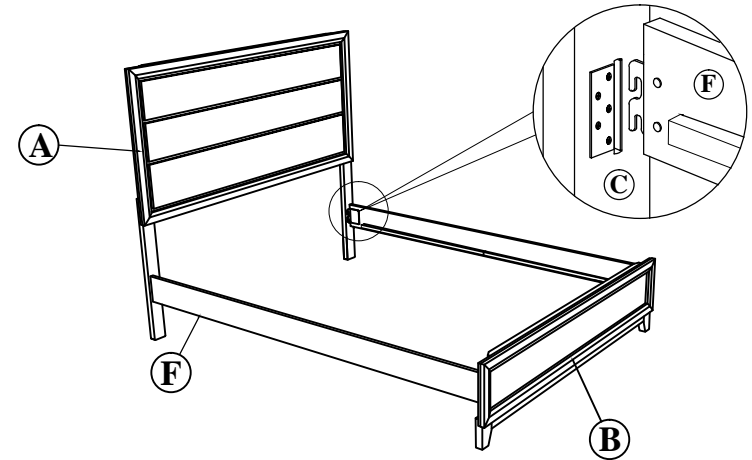

STEP 3 : Fix the Bed Slats Support (E) to Bed Slats (D) as Shown and fix the Bed Slats to Side Rail (F) by using CSK Screw (1). Loosen or Tighten the Adjuster as necessary to level the bed. Bed assembly should be done in final location to ensure stability.

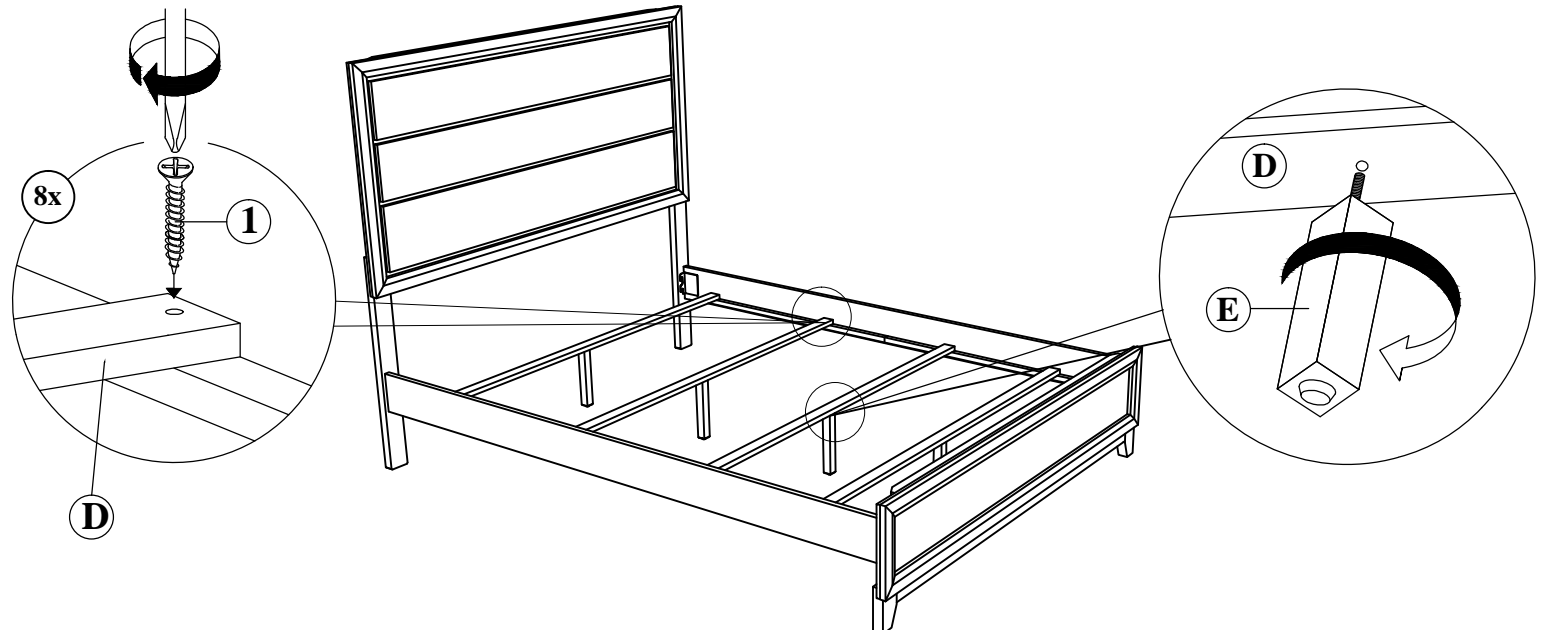

NOTE : MUST TIGHTEN SCREWS PERIODCALLY WITH USE SCREW WILL BECOME LOOSE CHECK TIGHTNESS OF ALL SCREW EVERY 6-8 WEEKS.

ASSEMBLY INSTRUCTIONS

**MODEL : KATE
NIGHT STAND**

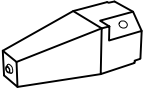

STEP 1 : Pull the top drawer and take out the Bunfoot carton (B). Attach the Bunfoot (B) at the bottom Night Stand (A) used JCBC (1)with Spring Washer (2) Flat Washer (3) and Tighten with Allen Wrench (4).

(Box 1)
BOX OF NIGHT STAND

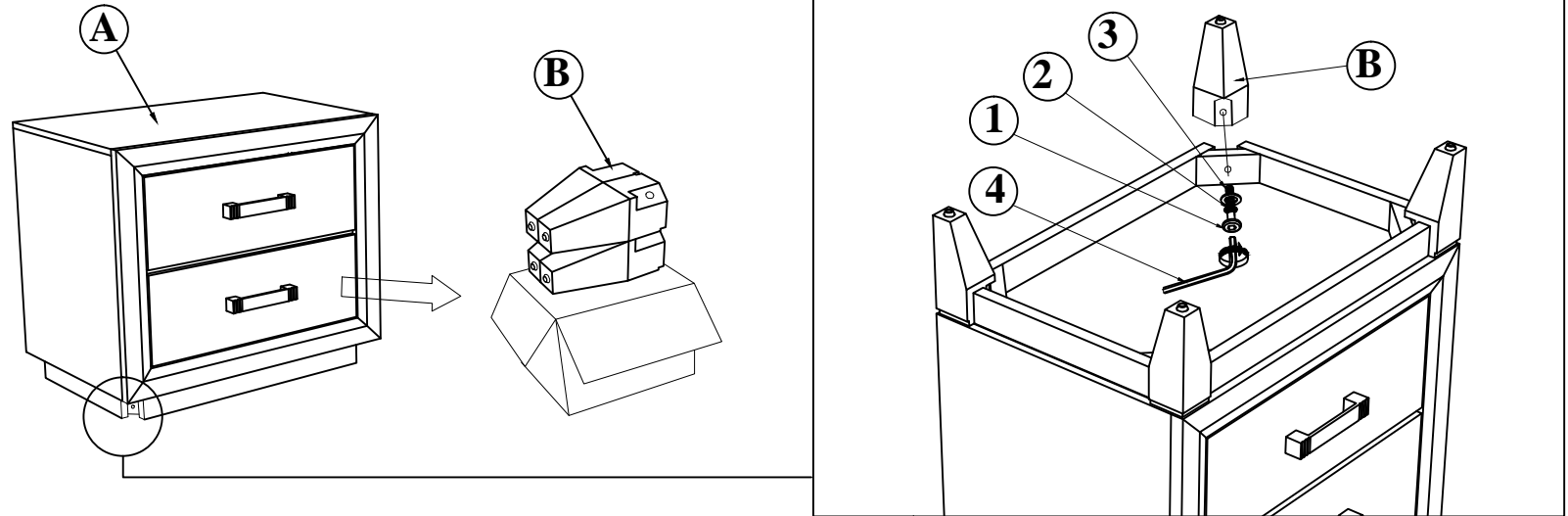
| No | ITEM | Qty |
|----|--|-------|
| A | NIGHT STAND  | 1 pc |
| B | BUN FOOT  | 4 pcs |

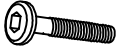

(Box 1)
HARDWARE LIST

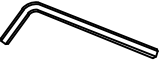
| No | ITEM | Qty |
|----|---|-------|
| 1 | JCBC M8 x 50mm  | 4 pcs |
| 2 | SPRING WASHER 5/16" Rbw  | 4 pcs |
| 3 | Flat Washer 5/16" ID x 22mm OD Blk  | 4 pcs |
| 4 | ALLEN KEY m5x65mm Blk  | 1 pc |



COMPLETED ASSEMBLY

NOTE : MUST TIGHTEN SCREWS PERIODICALLY WITH USE SCREW WILL BECOME LOOSE CHECK TIGHTNESS OF ALL SCREW EVERY 6-8 WEEKS.



ASSEMBLY INSTRUCTIONS

**MODEL :
KATE CHEST**

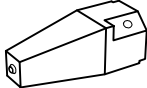
STEP 1 : Pull the top drawer and take out the Bunfoot carton (B). Attach the Bunfoot (B) at the bottom Chest (A) used JCBC (1) with Spring Washer (2) Flat Washer (3) and Tighten with Allen Wrench (4).

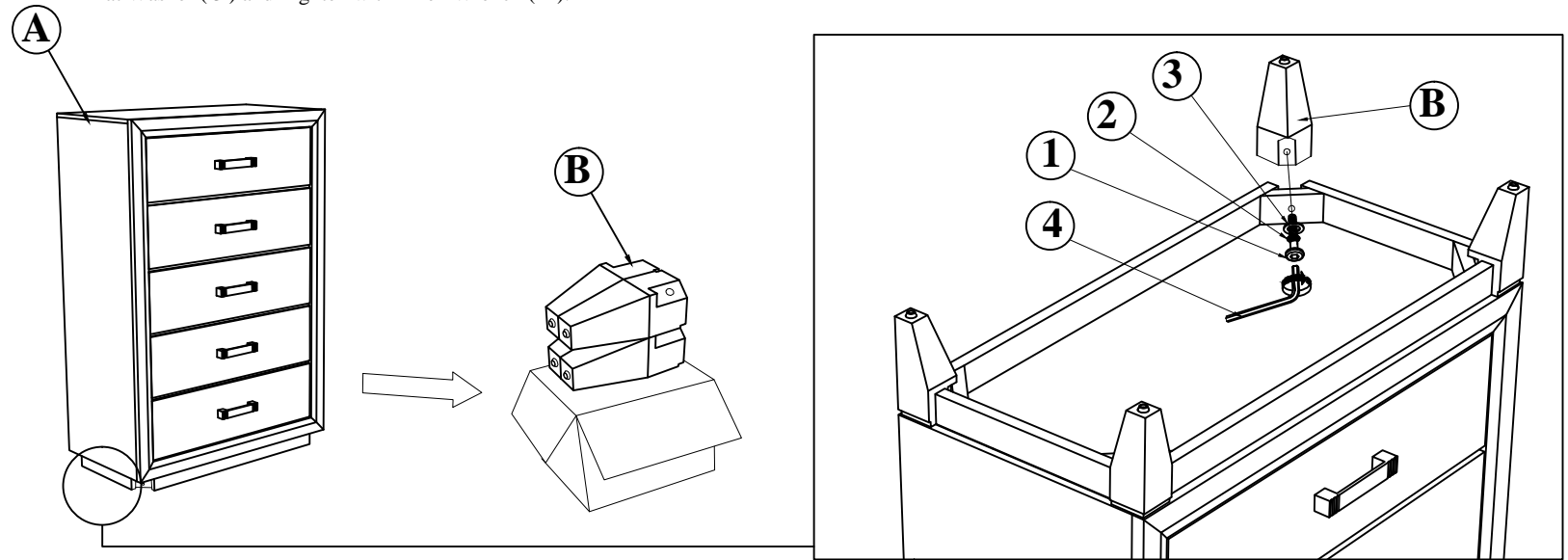
| (Box 1) BOX OF CHEST | | |
|--------------------------------|---|-------|
| No | ITEM | Qty |
| A | CHEST  | 1 pc |
| B | BUN FOOT  | 4 pcs |

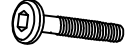

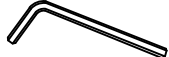
| (Box 1) HARDWARE LIST | | |
|---------------------------------|---|-------|
| No | ITEM | Qty |
| 1 | JCBC M8 x 50mm  | 4 pcs |
| 2 | SPRING WASHER 5/16" Rbw  | 4 pcs |
| 3 | Flat Washer 5/16" ID x 22mm OD Blk  | 4 pcs |
| 4 | ALLEN KEY m5x65mm Blk  | 1 pc |



COMPLETED ASSEMBLY

NOTE : MUST TIGHTEN SCREWS **PERIODICALLY** WITH USE SCREW WILL BECOME LOOSE CHECK TIGHTNESS OF ALL SCREW EVERY 6-8 WEEKS.

ASSEMBLY INSTRUCTIONS

**MODEL :KATE
DRESSER**

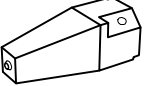

STEP 1 : Pull the top drawer and take out the Bunfoot carton (B). Attach the Bunfoot (B) at the bottom Dresser (A) used JCBC (1) with Spring Washer (2) Flat Washer (3) and Tighten with Allen Wrench (4).

(Box 1)
BOX OF CHEST

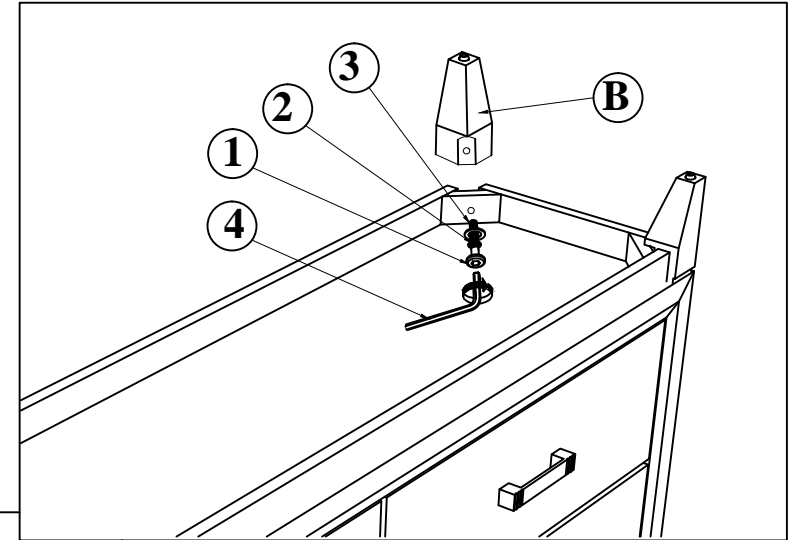
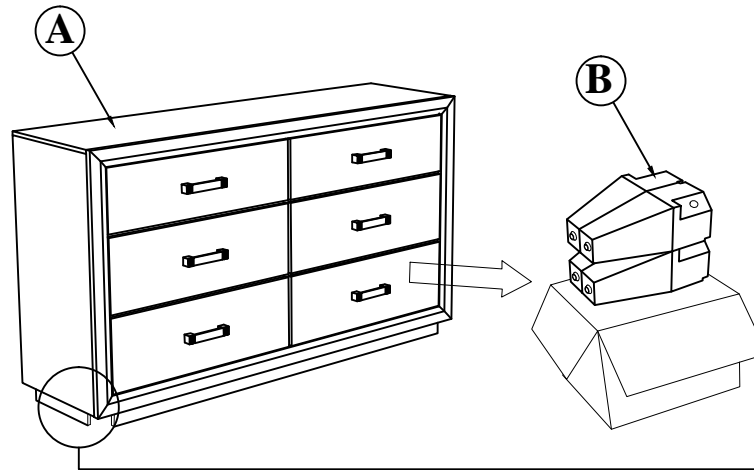
| No | ITEM | Qty |
|----|---|-------|
| A | DRESSER  | 1 pc |
| B | BUN FOOT  | 4 pcs |



(Box 1)
HARDWARE LIST

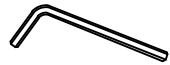

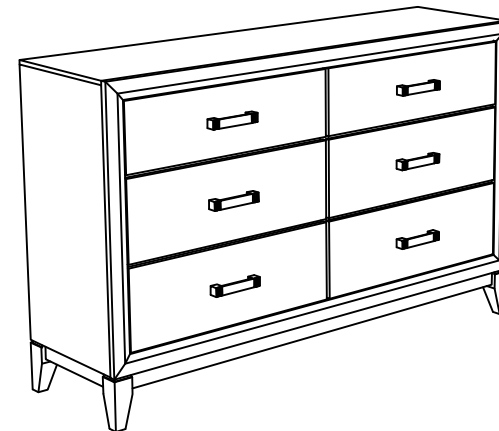

| No | ITEM | Qty |
|----|--|-------|
| 1 | JCBC M8 x 50mm  | 4 pcs |
| 2 | SPRING WASHER 5/16" Rbw  | 4 pcs |
| 3 | Flat Washer 5/16"ID x 22mmOD Blk  | 4 pcs |
| 4 | ALLEN KEY m5x65mm Blk  | 1 pc |

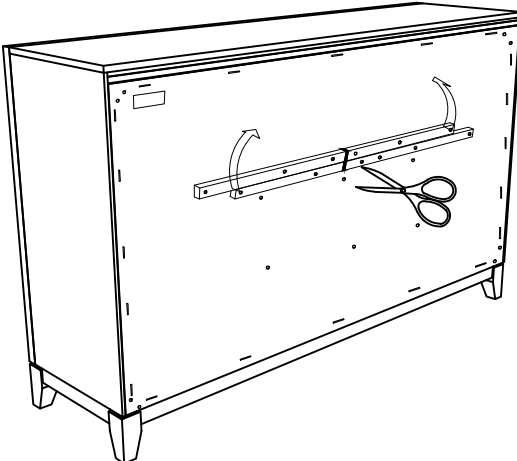
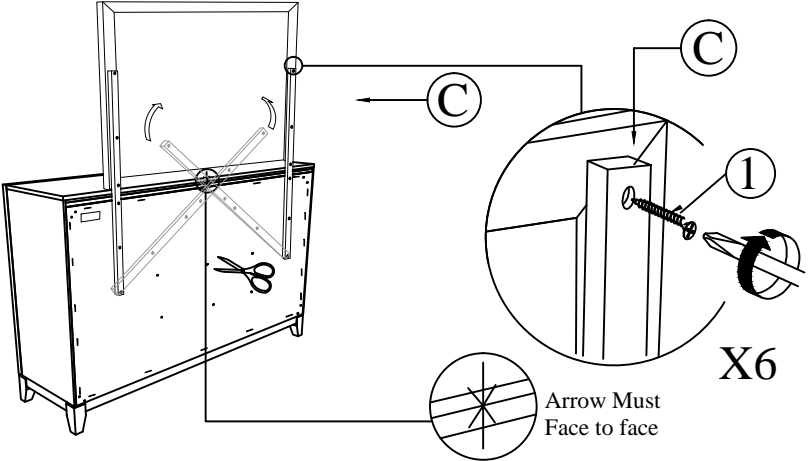
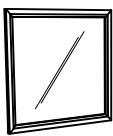

COMPLETED ASSEMBLY

NOTE : MUST TIGHTEN SCREWS **PERIODICALLY** WITH USE SCREW WILL BECOME LOOSE CHECK TIGHTNESS OF ALL SCREW EVERY 6-8 WEEKS.

ASSEMBLY INSTRUCTIONS

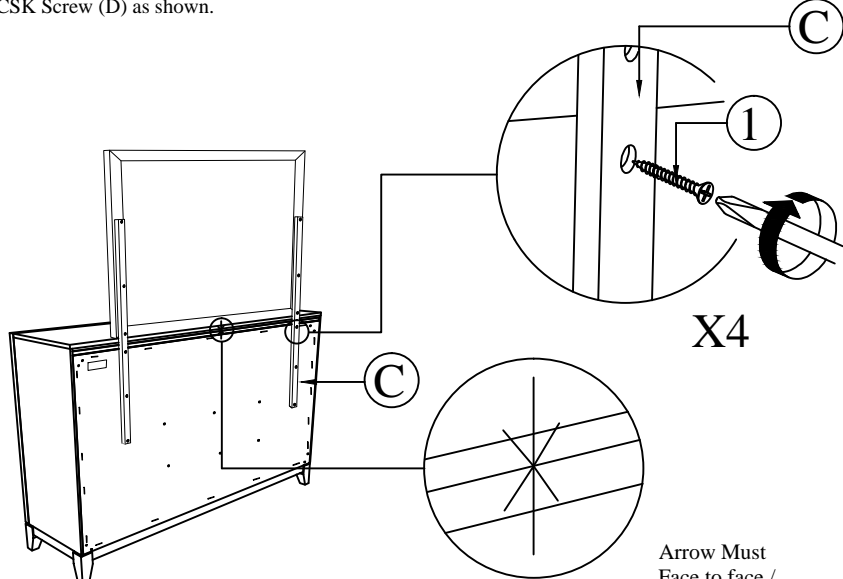
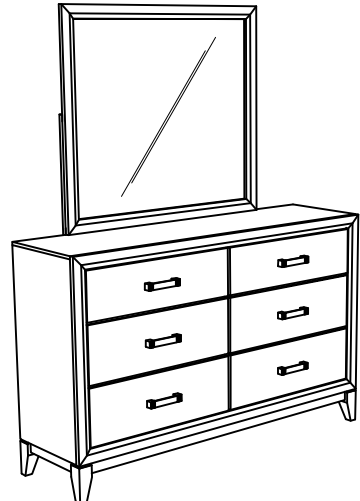
| | | | | |
|---|--|--------|---|---|
| MODEL: KATE DRESSER & MIRROR | | | <p>STEP 1 / ETAPE 1 : Cut of the Raffia String from the back of DRESSER (B).</p>  | <p>STEP 2 / ETAPE 2 : Turn the MIRROR SUPPORT RAIL (C) upward at the back of DRESSER (B), Place the MIRROR FRAME (A) on the top of DRESSER (B). Tighnten with CSK Screw (D).</p>  <p style="text-align: right;">X6 Arrow Must Face to face</p> |
| <p>(Box 1) BOX OF MIRROR</p> | | | | |
| NO | ITEM | QTY | | |
| A | MIRROR  | 1 PC | | |
| <p>(Box 2) BOX OF DRESSER</p> | | | | |
| NO | ITEM | QTY | | |
| B | DRESSER  | 1 PC | | |
| C | MIRROR SUPPORT RAIL  | 2 PCS | | |
| <p>(Box 1) BOX OF MIRROR</p> | | | | |
| NO | ITEM | QTY | | |
| 1 | CSK SCREW M4 X 32MM  | 10 PCS | | |
| | | | <p>STEP 3 / ETAPE 3 : Tightnen the CSK Screw (D) as shown.</p>  <p style="text-align: right;">X4 Arrow Must Face to face / Repere d' alignment</p> |  <p style="text-align: right;"><u>COMPLETED</u> <u>ASSEMBLY</u></p> |

NOTE : MUST TIGHTEN SCREWS PERIODCALLY WITH USE SCREW WILL BECOME LOOSE CHECK TIGHTNESS OF ALL SCREW EVERY 6-8 WEEKS.

INSTRUCTIONS D'ASSEMBLAGE

MODÈLE : 0170A
GRAND & COMPLET LIT (4 + 4)

(Cart. 1)
CARTON DE TÊTE & PIED DE LIT

| N° | Liste de Pièces | Qté |
|----|------------------------------|--------|
| A | Tête de lit | 1 pce |
| B | Pied de lit | 1 pce |
| C | Pied de la Tête de Lit (D/G) | 2 pces |
| D | Lattes | 4 pces |
| E | Soutien de Latte | 4 pces |

(Cart. 2)
CARTON DE LONGERON

| N° | Liste de Pièces | Qté |
|----|-----------------|--------|
| F | Longeron | 2 pces |

(Cart. 1)
QUINCAILLERIE

| N° | Liste de Pièces | Qté |
|----|--------------------------------------|--------|
| 1 | Vis Csk M4 x 32mm | 8 pces |
| 2 | BOULON JCBC M6 x 30mm | 6 pces |
| 3 | Rondelle A Ressort 1/4" Rbw | 6 pces |
| 4 | Rondelle Plate 1/4" ID x 13mm OD Nre | 6 pces |
| 5 | CLÉ ALLEN m4 x 65mm NRE | 1 pce |
| 6 | CLÉ ALLEN m5 x 65mm NRE | 1 pce |

ÉTAPE 1 : Attacher les Pieds de la TDL (C) à la Tête de lit (A) comme indiqué avec des BOULONS JCBC (2) des Rondelles à ressort (3), des Rondelles plates (4) en utilisant la CLE ALLEN (5).

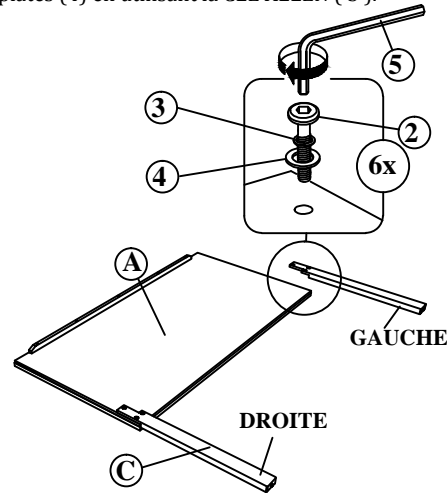

ÉTAPE 2 : Accrocher le LONGERON (F) à la TÊTE DE LIT (A) et appuyer fermement. Répéter étape 2 pour accrocher l'autre coté du longeron au PIED DE LIT (B).

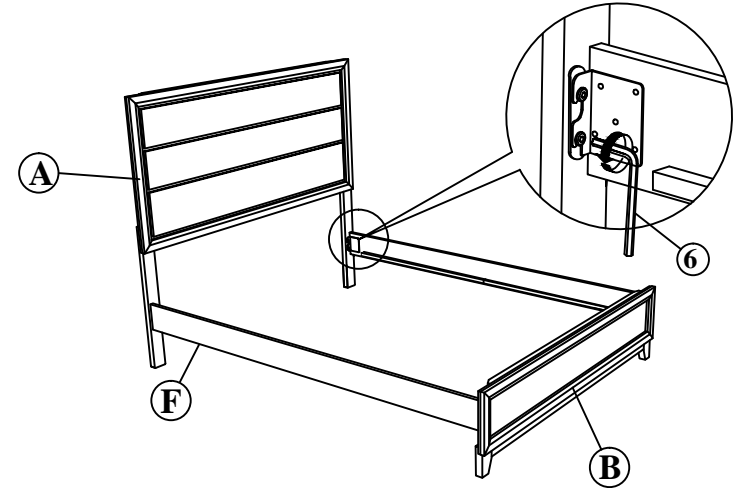

ÉTAPE 3 : Serrer les 4 coin avec une clé Allen (6). Fixer la jambe de lattes de lit (E), à double Barrette (D) comme indiqué . Installer le lit de lamelles (D) à l'autre rail (F) et serrer avec la vis Csk (1) au schéma indiqué. (Remarque : L'INSTALLATION DOIT FAIT À L'ENDROIT DÉCIDÉ POUR LE LIT D'OBTENIR UNE STABILITÉ PARFAITE)

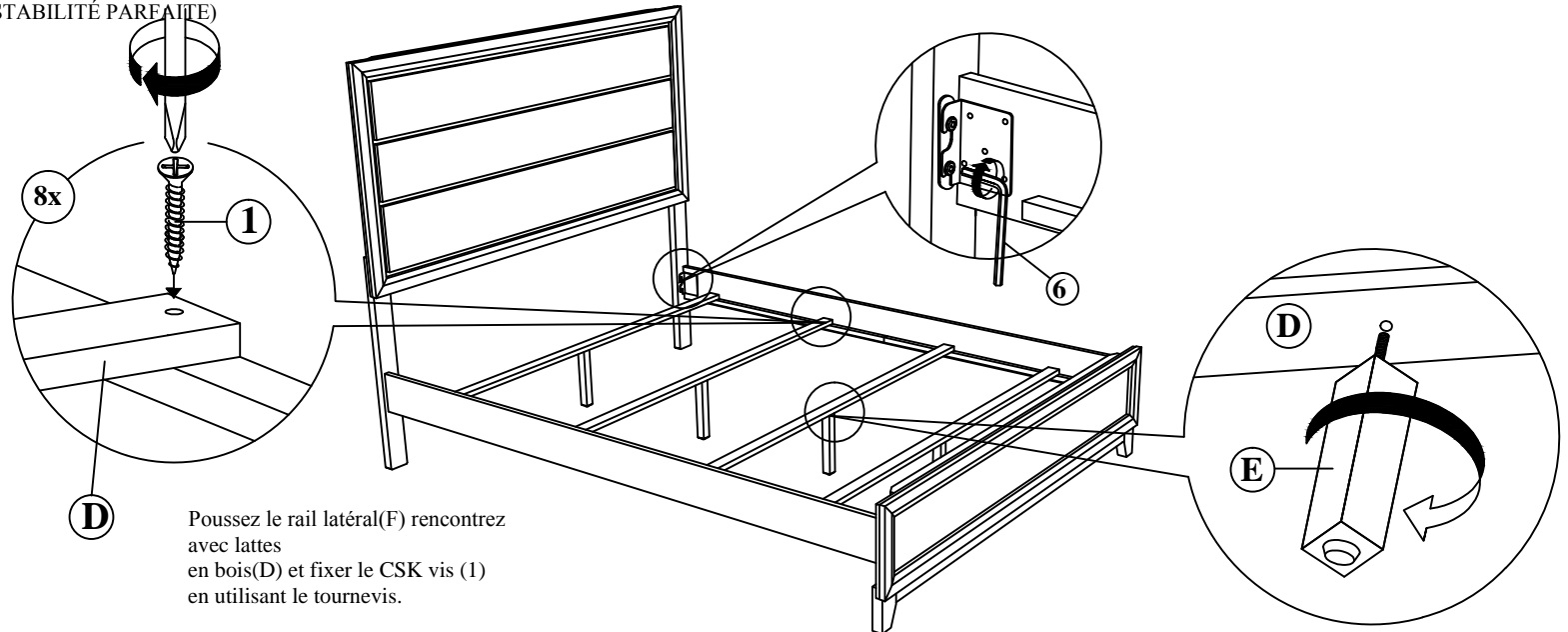

REMARQUE : RESERRER LES VIS RÉGULIÈREMENT. À L'USAGE, LES VIS SE DESERRENT. VÉRIFIER QUE LES VIS SOIENT SERRÉES TOUTES LES 6-8 SEMAINES.

INSTRUCTIONS D'ASSEMBLAGE

MODÈLE :0170A
COMMODE & MIROIR

(Cart. 1)
CARTON MIROIR

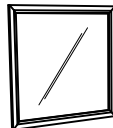
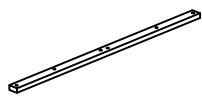
| N° | PIECE | Qté |
|----|--|--------|
| A | MIROIR  | 1 PCE |
| B | RENFORT DU MIROIR  | 2 PCES |

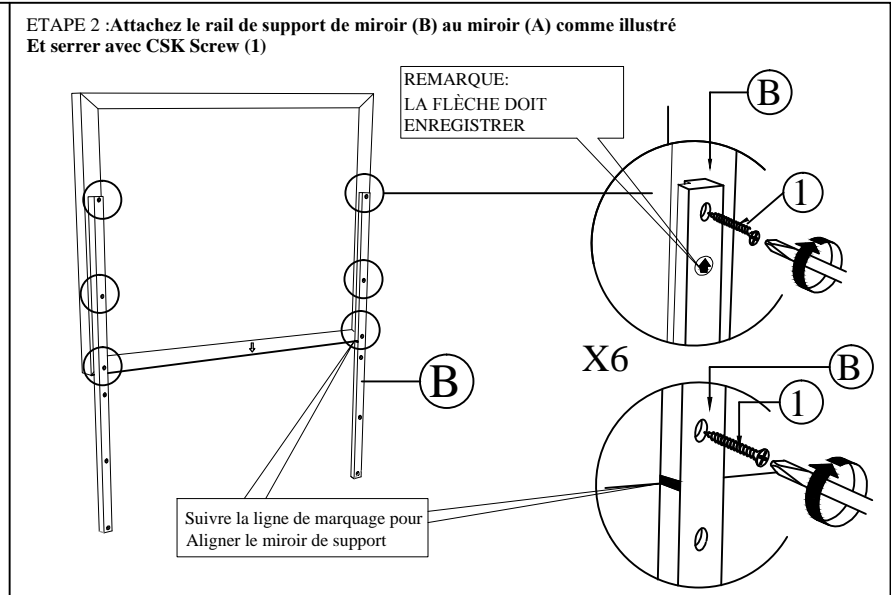
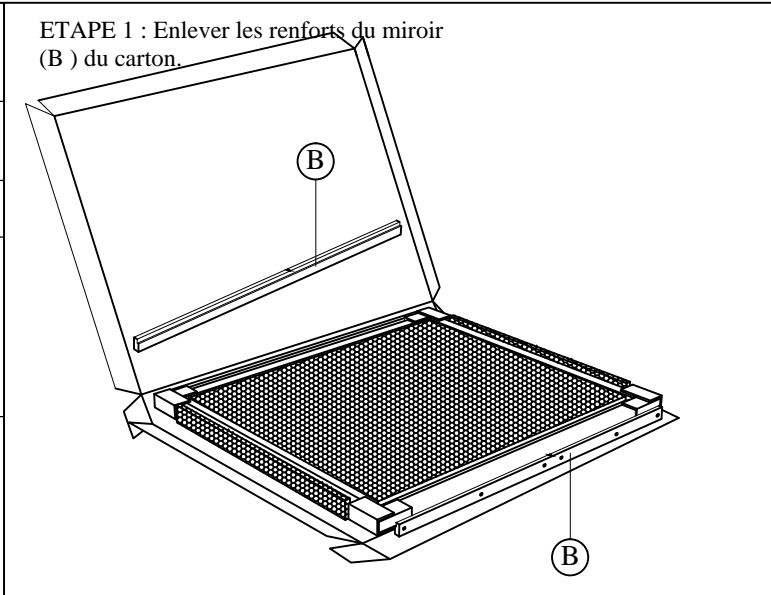

(Cart. 2)
CARTON COMMODE

| N° | PIECE | Qté |
|----|---|-------|
| C | COMMODE  | 1 PCE |

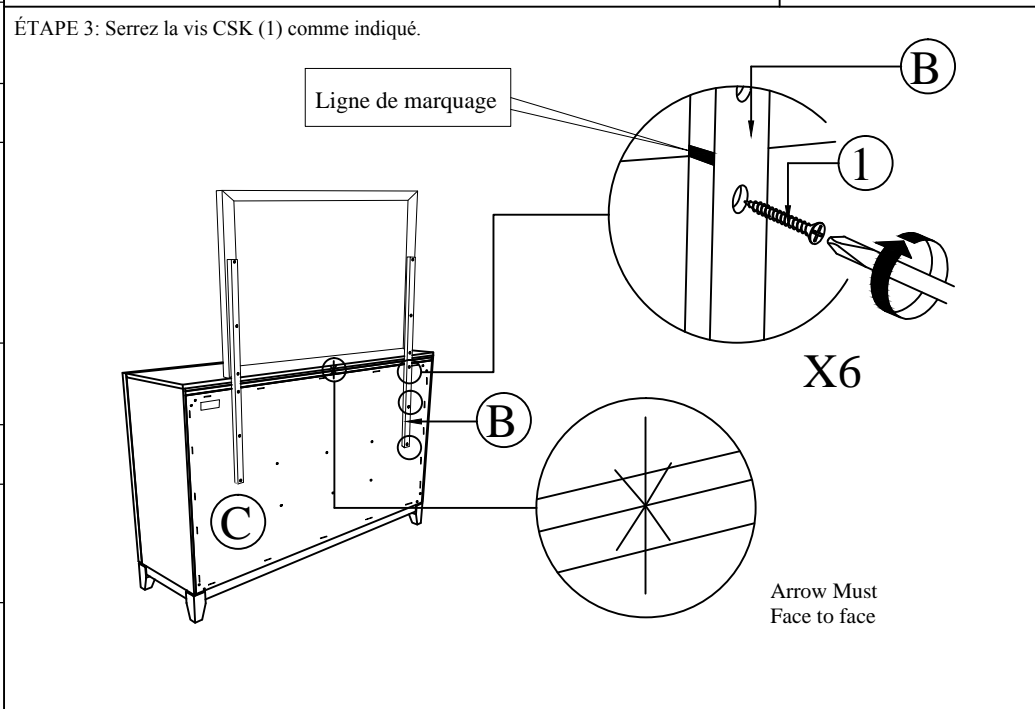

(Cart. 1)
CARTON MIROIR

| N° | PIECE | Qté |
|----|--|---------|
| 1 | VIS CSK M4 X 32MM  | 12 PCES |

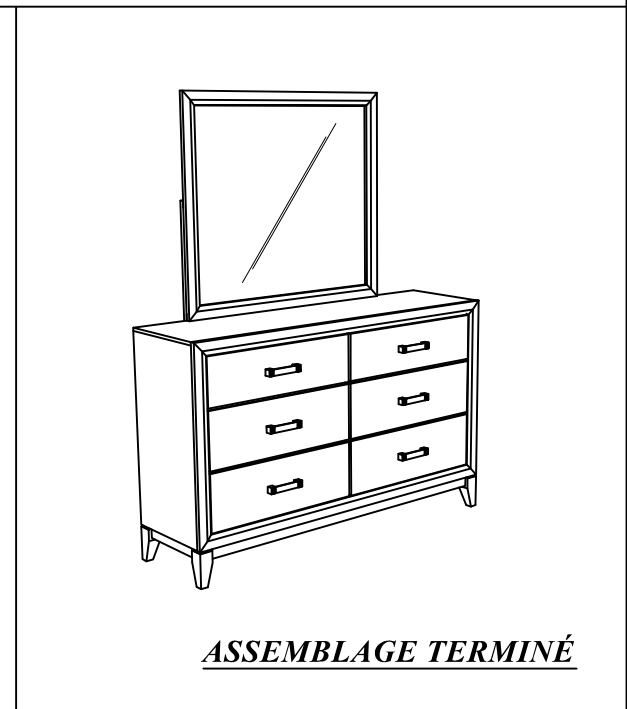

NOTE : MUST TIGHTEN SCREWS PERIODCALLY WITH USE SCREW WILL BECOME LOOSE CHECK TIGHTNESS OF ALL SCREW EVERY 6-8 WEEKS.

ASSEMBLY INSTRUCTIONS

MODÈLE : 0170A
COMMODE

ÉTAPE 1: Tirez le tiroir et sortez le carton Bunfoot (B). Fixez le Bunfoot (B) au pied de la partie inférieure (A) utilisé JCBC (1) avec Spring Washer (2) Rondelle plate (3) et serrage avec clé Allen (4).

(Carton1)

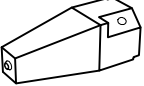

BOITE DE COMMODE

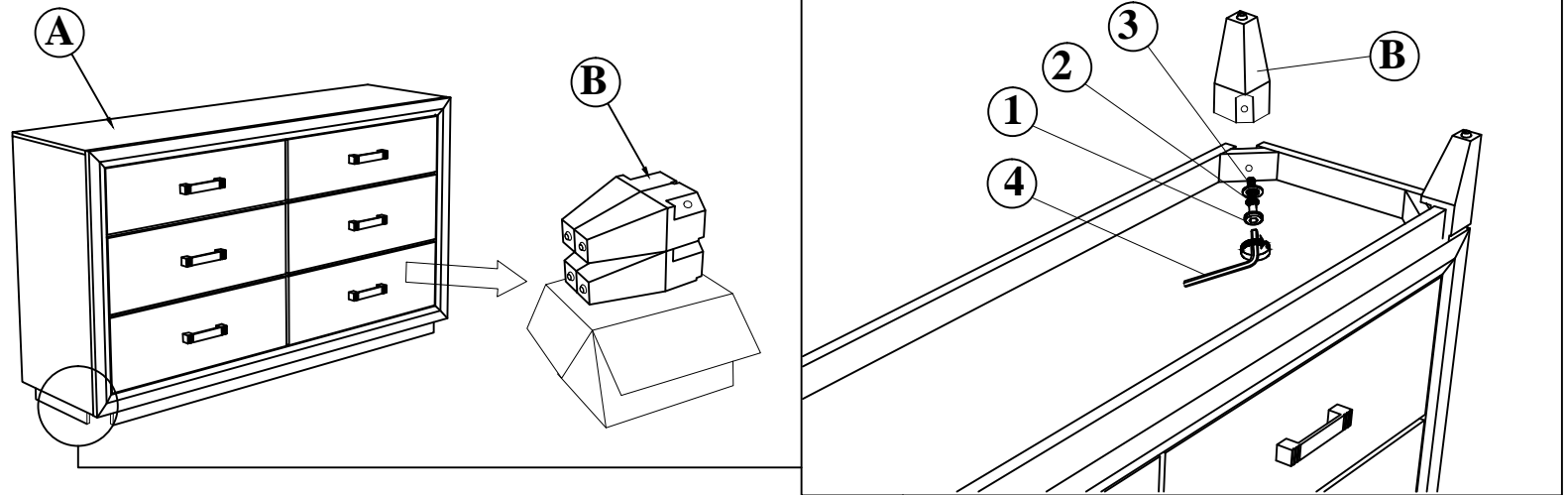
| N° | Liste de Pièces | Qté |
|----|---|--------|
| A | COMMODE  | 1 pce |
| B | Pied de pain  | 4 pces |



(Cart. 1)

QUINCAILLERIE

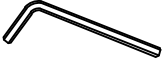
| N° | Liste de Pièces | Qté |
|----|---|--------|
| 1 | BOULON JCBC M6 x 50mm  | 4 pces |
| 2 | Rondelle A Ressort 1/4" Rbw  | 4 pces |
| 3 | Rondelle Plate 1/4" ID x 13mm OD Nre  | 4 pces |
| 4 | CLÉ ALLEN m4 x 65mm NRE  | 1 pce |

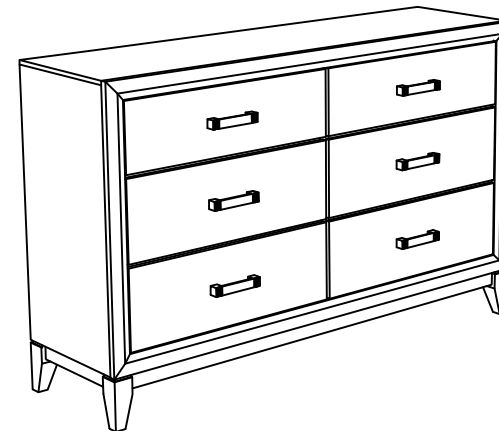

COMPLETED ASSEMBLY

REMARQUE : RESERRER LES VIS RÉGULIÈREMENT. À L'USAGE, LES VIS SE DESERRENT. VÉRIFIER QUE LES VIS SOIENT SERRÉES TOUTES LES 6-8 SEMAINES.

ASSEMBLY INSTRUCTIONS

MODÈLE : 0170A
COMMODE

(Carton1)

BOITE DE COMMODE

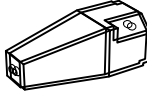

| N° | Liste de Pièces | Qté |
|----|---|--------|
| A | <p>COMMODE</p>  | 1 pce |
| B | <p>Pied de pain</p>  | 4 pces |

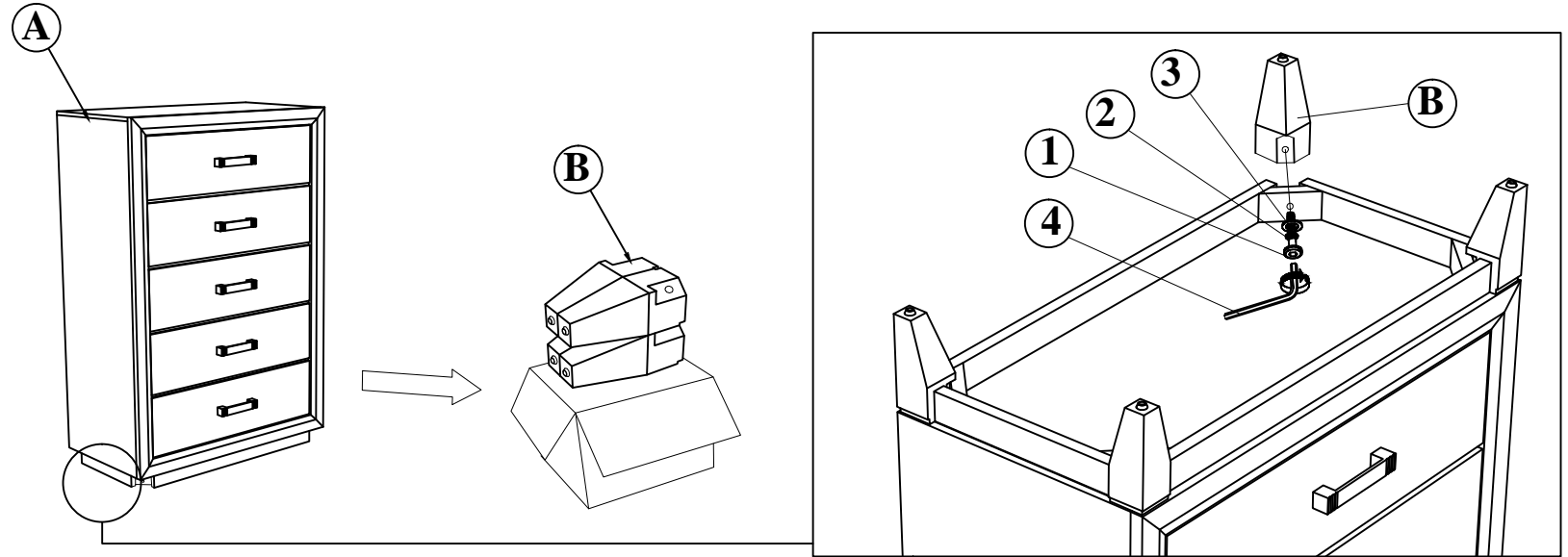
ÉTAPE 1: Tirez le tiroir et sortez le carton Bunfoot (B). Fixez le Bunfoot (B) au pied de la partie inférieure (A) utilisé JCBC (1) avec Spring Washer (2) Rondelle plate (3) et serrage avec clé Allen (4).

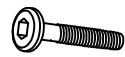

(Cart. 1)

QUINCAILLERIE

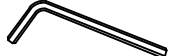
| N° | Liste de Pièces | Qté |
|----|---|--------|
| 1 | <p>BOULON JCBC M6 x 50mm</p>  | 4 pces |
| 2 | <p>Rondelle A Ressort 1/4" Rbw</p>  | 4 pces |
| 3 | <p>Rondelle Plate 1/4" ID x 13mm OD Nre</p>  | 4 pces |
| 4 | <p>CLÉ ALLEN m4 x 65mm NRE</p>  | 1 pce |



COMPLETED ASSEMBLY

REMARQUE : RESERRER LES VIS RÉGULIÈREMENT. À L'USAGE, LES VIS SE DESERRENT. VÉRIFIER QUE LES VIS SOIENT SERRÉES TOUTES LES 6-8 SEMAINES.

INSTRUCTIONS D'ASSEMBLAGE

MODÈLE : 0170A LA TABLE DE NUIT

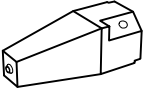

ÉTAPE 1: Tirez le tiroir et sortez le carton Bunfoot (B). Fixez le Bunfoot (B) au pied de la partie inférieure (A) utilisé JCBC (1) avec Spring Washer (2) Rondelle plate (3) et serrage avec clé Allen (4).

(Carton1)
BOITE DE NUIT

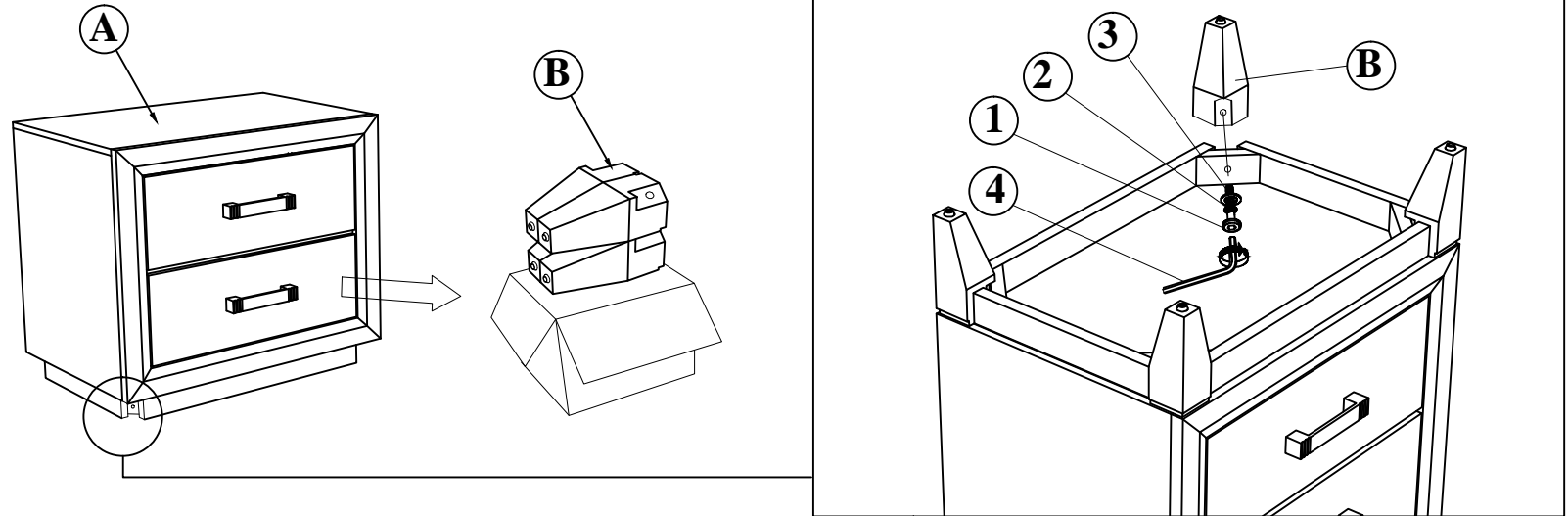
| N° | Liste de Pièces | Qté |
|----|---|--------|
| | LA TABLE DE NUIT | |
| A |  | 1 pce |
| B | Pied de pain  | 4 pces |

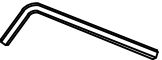

(Cart. 1)
QUINCAILLERIE

| N° | Liste de Pièces | Qté |
|----|--|--------|
| 1 | BOULON JCBC M6 x 50mm  | 4 pces |
| 2 | Rondelle A Ressort 1/4" Rbw  | 4 pces |
| 3 | Rondelle Plate 1/4" ID x 13mm OD Nre  | 4 pces |
| 4 | CLÉ ALLEN m4 x 65mm NRE  | 1 pce |

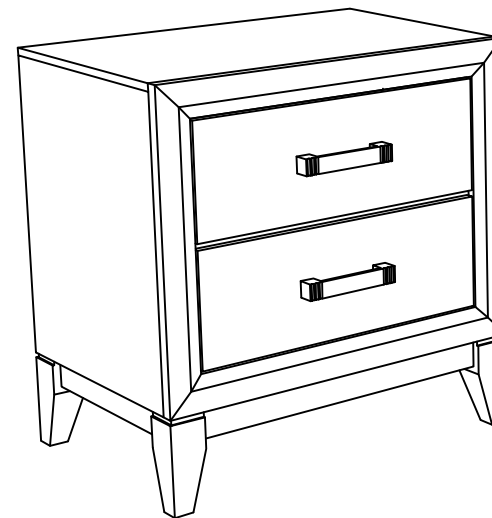

COMPLETED ASSEMBLY

REMARQUE : RESERRER LES VIS RÉGULIÈREMENT. À L'USAGE, LES VIS SE DESERRENT. VÉRIFIER QUE LES VIS SOIENT SERRÉES TOUTES LES 6-8 SEMAINES.